



NPN Silicon Epitaxial Planar Transistor

for high current switching, interface circuit and driver circuit application.

Feature

- With built-in bias resistors
- Simplify circuit design
- Reduce a quantity of parts and manufacturing Process

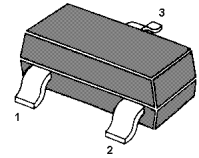
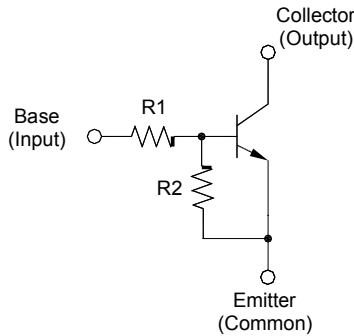

1. Base 2. Emitter 3. Collector
SOT-23 Plastic Package

Resistor Values

Type	R1 (KΩ)	R2 (KΩ)
MMBTRC241SS	1	1
MMBTRC242SS	2.2	2.2
MMBTRC243SS	4.7	4.7
MMBTRC244SS	10	10
MMBTRC245SS	1	10
MMBTRC246SS	2.2	10

Absolute Maximum Ratings (T_a = 25 °C)

Parameter	Symbol	Value	Unit
Output Voltage	V _O	50	V
Input Voltage	V _I	10, -10	V
		12, -10	
		20, -10	
		30, -10	
		10, -5	
		12, -6	
Output Current	I _O	300	mA
Total Power Dissipation	P _{tot}	200	mW
Junction Temperature	T _j	150	°C
Storage Temperature Range	T _{stg}	- 55 to + 150	°C



Characteristics at $T_a = 25\text{ }^\circ\text{C}$

Parameter	Symbol	Min.	Typ.	Max.	Unit
DC Current Gain at $V_o = 5\text{ V}$, $I_o = 50\text{ mA}$	G _I	33	-	-	-
MMBTRC241SS		39	-	-	-
MMBTRC242SS		47	-	-	-
MMBTRC243SS		56	-	-	-
MMBTRC244SS		56	-	-	-
MMBTRC246SS		56	-	-	-
Output Cutoff Current at $V_o = 30\text{ V}$	$I_{O(OFF)}$	-	-	10	μA
Input Current at $V_i = 5\text{ V}$	I _I	-	-	7.2	mA
MMBTRC241SS		-	-	3.8	
MMBTRC242SS		-	-	1.8	
MMBTRC243SS		-	-	0.88	
MMBTRC244SS		-	-	7.2	
MMBTRC246SS		-	-	3.6	
Output Voltage at $I_o = 10\text{ mA}$, $I_i = 0.5\text{ mA}$	$V_{O(ON)}$	-	-	0.3	V
Input Voltage (ON) at $V_o = 0.3\text{ V}$, $I_o = 20\text{ mA}$	$V_{I(ON)}$	-	-	3	V
MMBTRC241SS		-	-	3	
MMBTRC242SS		-	-	3	
MMBTRC243SS		-	-	3	
MMBTRC244SS		-	-	3	
MMBTRC246SS		-	-	2	
Input Voltage (OFF) at $V_o = 5\text{ V}$, $I_o = 0.1\text{ mA}$	$-V_{I(OFF)}$	0.5	-	-	V
MMBTRC241SS~244SS MMBTRC245SS~246SS		0.3	-	-	
Transition Frequency at $V_o = 10\text{ V}$, $I_o = 5\text{ mA}$, $f = 100\text{ MHz}$	$f_T^{1)}$	-	200	-	MHz

1) Characteristic of transistor only.



CHINA BASE
INTERNATIONAL

SOT-23



MMBTRC241SS-MMBTRC246SS

www.china-base.com.hk

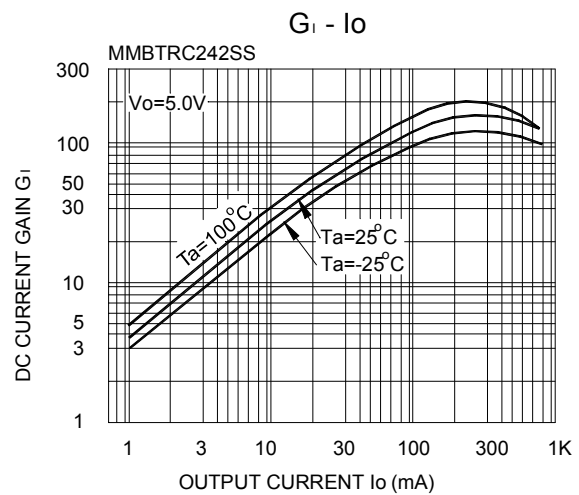
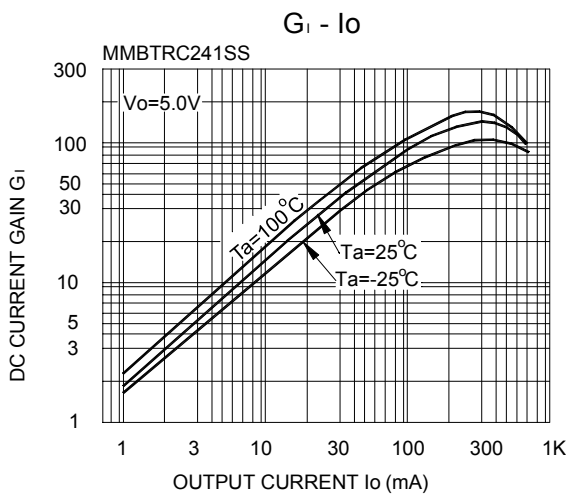
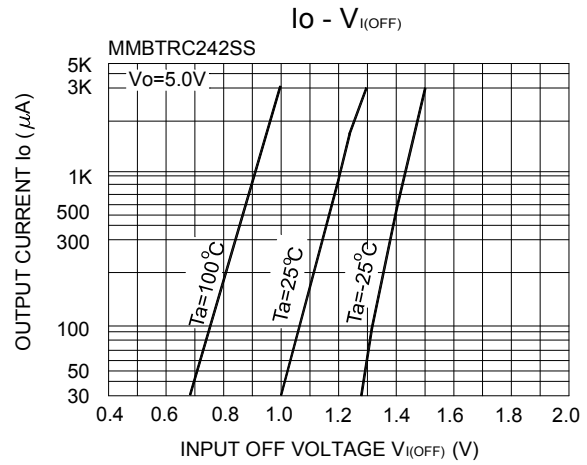
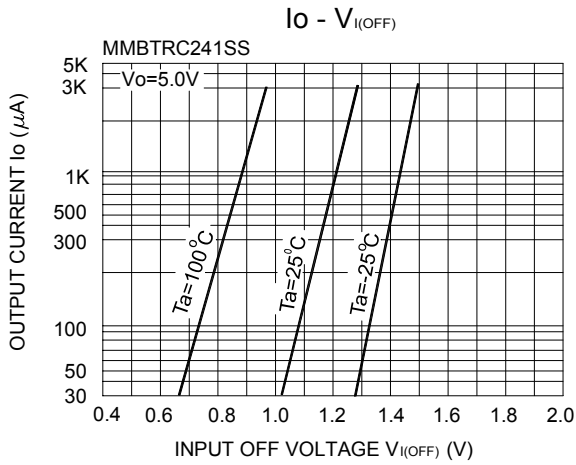
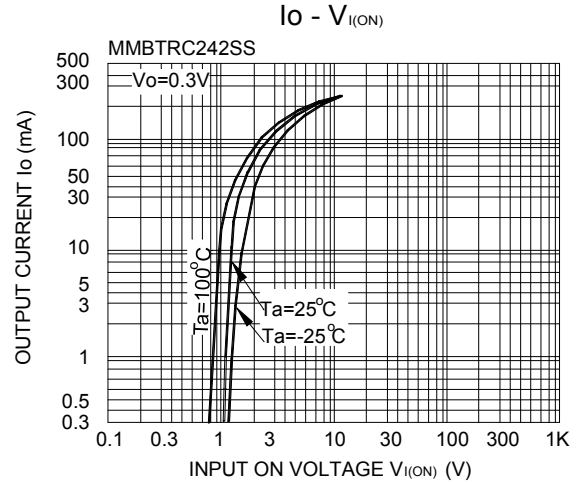
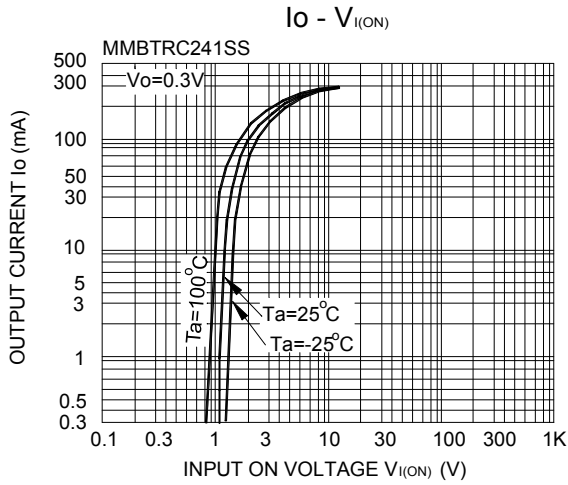

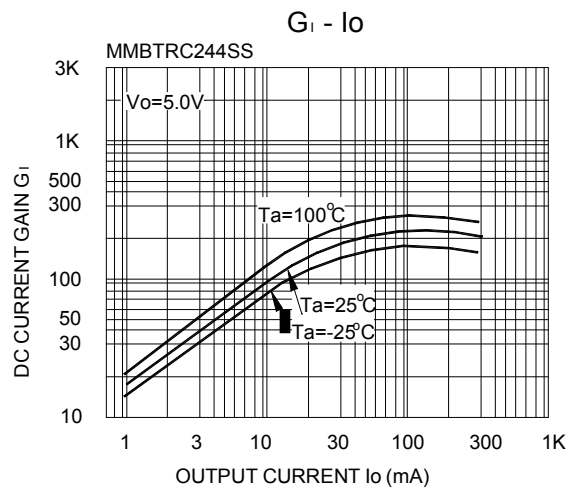
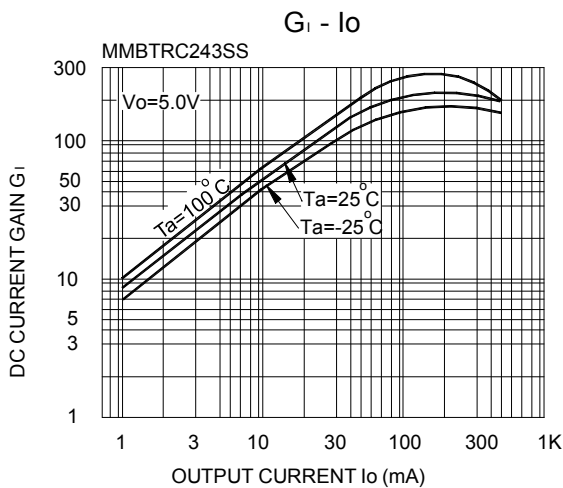
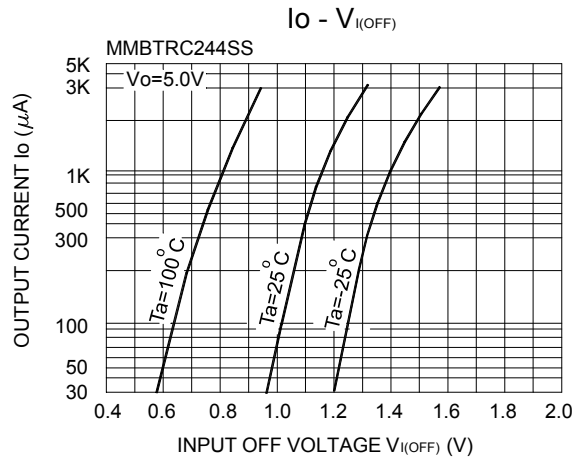
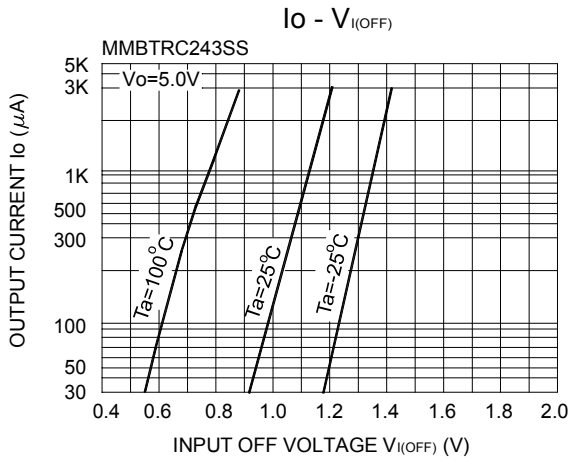
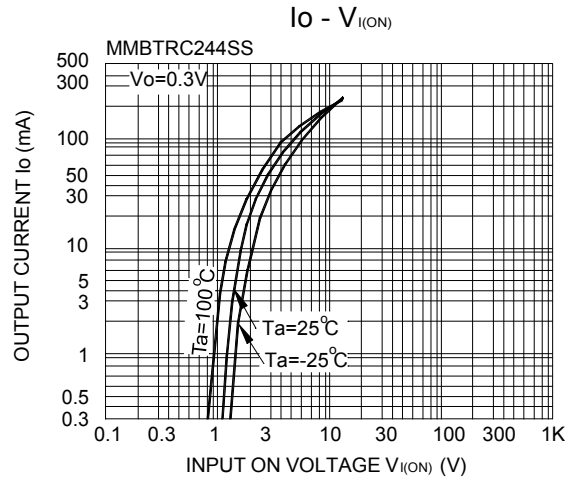
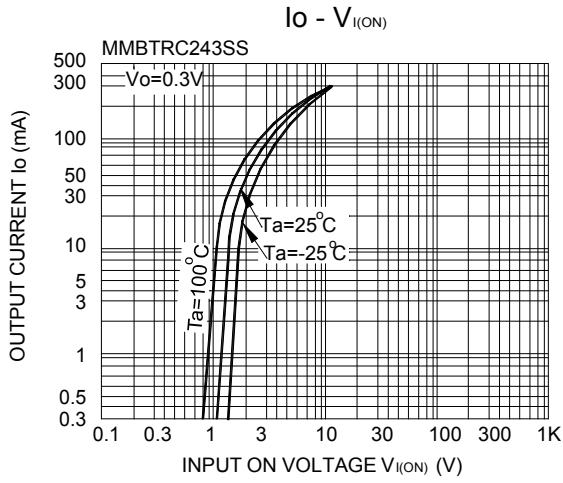

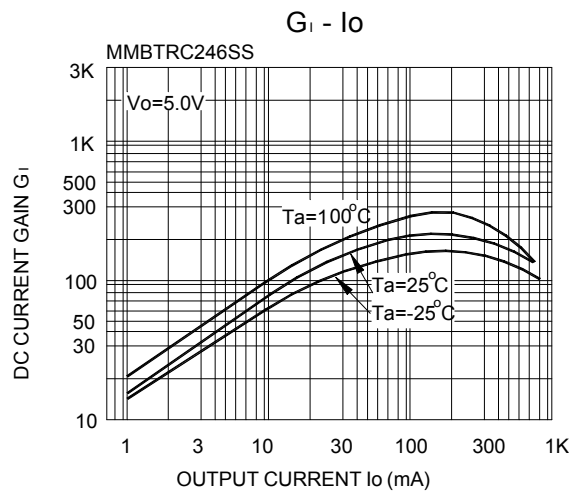
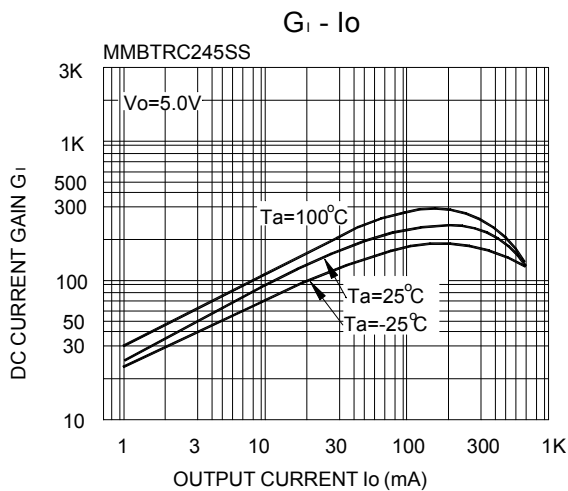
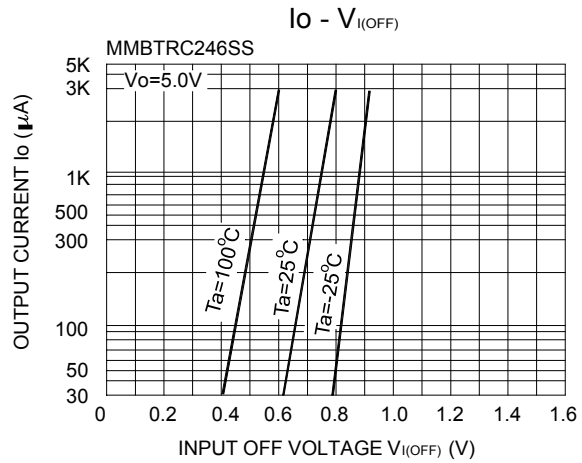
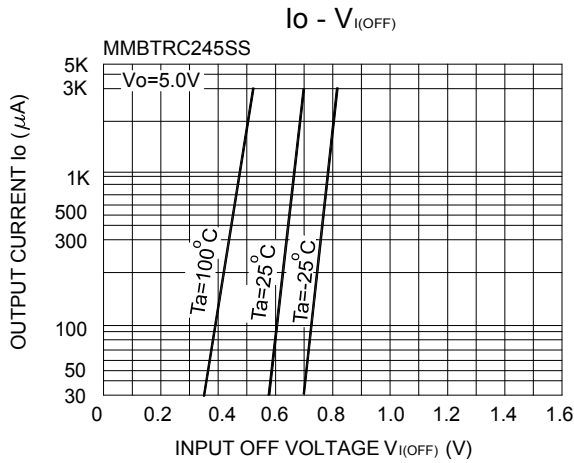
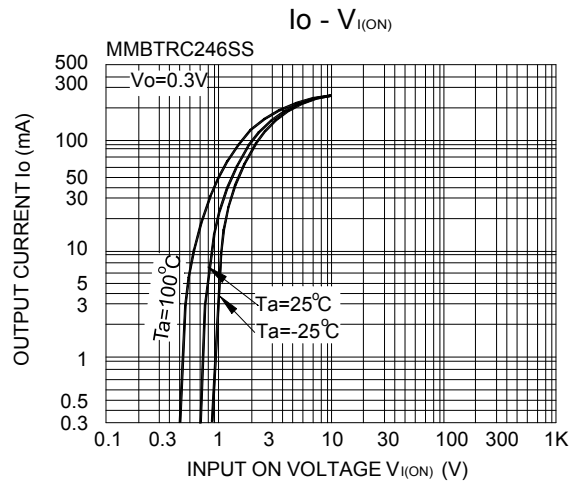
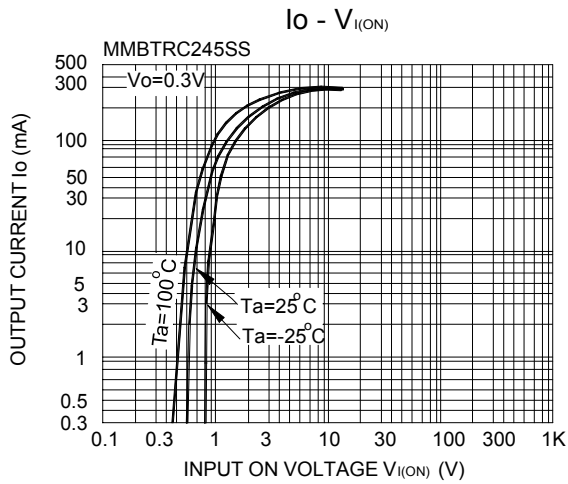



PACKAGE OUTLINE

Plastic surface mounted package; 3 leads

SOT-23

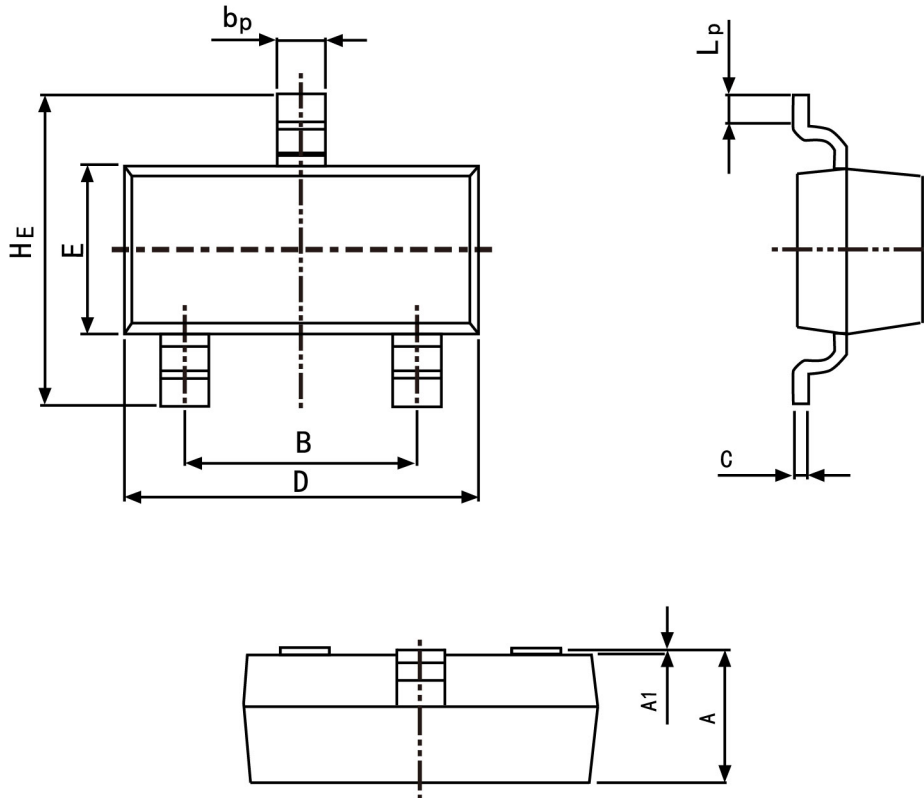

Symbol	Dimension in Millimeters	
	Min	Max
A	0.95	1.40
B	1.78	2.04
b_p	0.35	0.50
C	0.08	0.19
D	2.70	3.10
E	1.20	1.65
HE	2.20	3.00
A_1	0.100	0.013
L_p	0.20	0.50